



## Operating Instructions

# CHARGER 620B

Synchronous Rectification and microprocessor controlled high performance rapid charger/balancer for LiPo, LiFe battery packs with cell balancer.

Charge current up to 3A, 50W, for 2-6 LiPo/LiFe cells



## Chargery Power Co., Ltd.

### Head Office

**Add:** Room 20B, Haihui building, Nanhai Avenue, NanShan, ShenZhen, China

**Zip code:** 518054

**Tel:** +86 755 2643 6165

**Fax:** +86 755 2641 2865

**Email:** Jasonwang3a@163.com

**Web:** www.chargery.com

Welcome to the CHARGER 620B intelligent balance charger designed especially for 2 to 6 LiPo and LiFe cells. Please read the instructions carefully before using the charger.

## Special Features

### ■ Built-in balancer for LiPo and LiFe cells

The CY-620B has a built-in individual cell balancer. LiPo/LiFe batteries are automatically balanced during charging ensuring that when the battery is fully charged it is also properly balanced.

### ■ High power and high performance circuit

CY-620B employs the high efficiency circuit. As a result it can charge 6 series of LiPo batteries with maximal current of 3.0A. and the case is only 110\*68\*15.

### ■ Perfect safety design

#### Battery temperature limit

The battery temperature will rise by its internal chemical reaction. The charging process will be stopped forcibly when the temperature reach 60°C.

#### Charging time limit

The charging time can be restrained to prevent from any possible defect. When the charging time reach 5 hours, the charging process will be terminated.

#### Input voltage monitor

To protect the car battery using as input power from being damaged the input voltage always monitored. If it drops the 10.0V the charging process will be ended automatically.

At the same time, when you use the AC adaptor or transformer as input power, if the input voltage is more than 18V the charging process will be terminated to protect the CY-620B from being damaged.

### ■ Light and attractive AL alloy case

High-quality aluminum case is light and durable and very efficient to cool out the internal heat.

### ■ Protection function

- Reverse polarity and short circuit protection( input and output)
- Over charge and Over current protection
- For the battery voltage is less than 2V/cell (for LiFe) or 2.5V/cell (for LiPo), the CY-620B do not charge to prevent battery damaged.

### ■ 6 LEDs indicate charging current

### ■ 6 LEDs display each cell in balancing

### ■ 1 LED indicate the charging status

### ■ With Special Connector Conversion Board(CCB-7KT-XH, CCB-7KT-EH, CCB-7BC, CCB-723,CCB-723TPQF) and conversion wire(CEHN-7) to fit all kinds of battery connectors

### ■ Charge 2\*3S or 3\*2S battery packs simultaneously, the 2 or 3 packs should be connected to the CCB firstly, and then connect CCB to CY-620B.

## Specifications

- Applied battery type: LiPo battery and **LiFe battery**
- LiPo battery count: 2~6 cells
- Input voltage: DC 10-18V, 5A
- Charge current: 0.3~3A
- Balancing current: 200mA
- Dimensions: 110\*68\*15mm
- Weight: 130g

## Operating instructions

1. Connect the DC power or AC Adapter (12V, up to 5A) to the CY-620B. The charging Current LED (0.3A) will be on. All LEDs turns on and then off. The beeper will sound. The charger finished initializing.
2. Choose the battery type by moving the switch in the right of the CY-620B
3. Connect the 2 - 6S battery pack to the CY-620B through the Adapter Board (CCB-7KT) and conversion wire (CEHN-7). The Balance LED will flash; the quantity of flashed LED indicates the battery count. If the quantity is 5, the battery pack voltage is 18.5V (5S). If the battery pack is un-balanced, the corresponding LED will blink, start to balance.
4. Press the **Current Selection** button to adjust the charging current, the corresponding LED is on.  
During the charge, you can press the **Current Selection** button to adjust the current again.
5. Charging indicator LED should be **RED**.
6. When the charging indicator is GREEN, and all balance LEDs are off, the battery pack is fully charged and balanced. When the battery is fully charged, the beeper will sound 10 times.
7. **While charge is over, if you want to charge another battery with the same battery type (LiPo or LiFe), please unplug the full battery, and then connect the new battery.**

**But if the new battery is different battery type with the full battery, such as the new battery is LiFe battery, and the full battery just charged is LiPo battery. Please operate as below:**

- a) **Unplug the full battery**
- b) **Move the switch of battery type to right position.**
- c) **Connect the new battery to the unit.**

While charging, the built-in balancer will monitor the voltage of each cell of the battery pack and control the charging current feeding to each cell to balance the voltage.

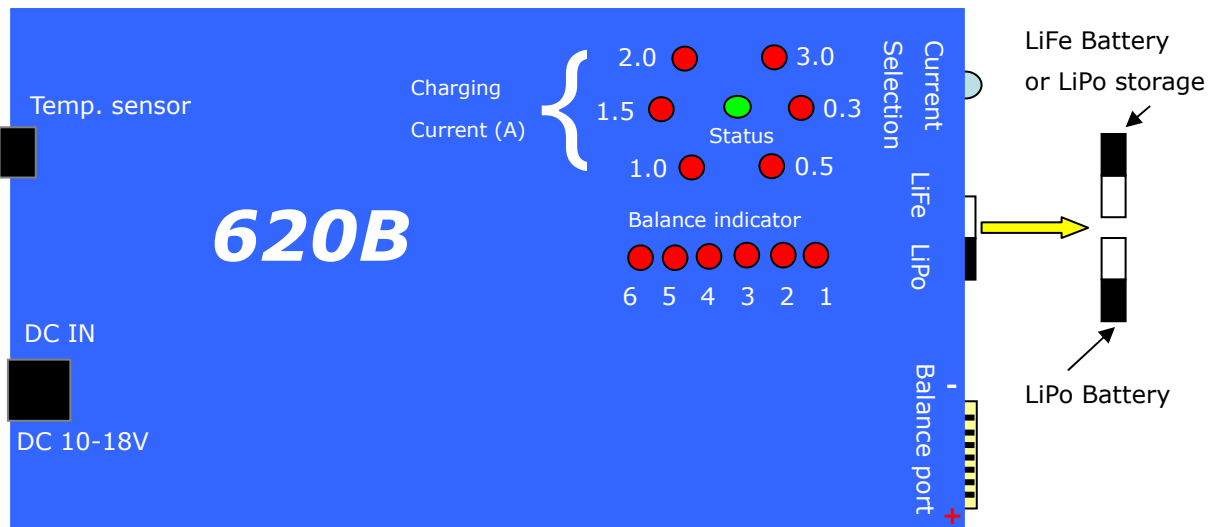

There is a **Current Selection button** on the right of the CY-620B, press the button to choose the charging current, 6 types of current is be used for the different capacity, we suggest the charging current is no more than 1C, if the battery capacity is 1000mAh, the charging current is lower than 1000mA.

And switch is for choosing the battery type, lithium polymer or Li-ion battery and LiFe battery cell can be charged.

For the LiPo battery or li-ion battery, the full charged voltage is 4.2V, and for the LiFe battery, the voltage is 3.7V.

If you need charge the lipo battery to be stored, please choose LiFe battery mode. This is a very useful feature.



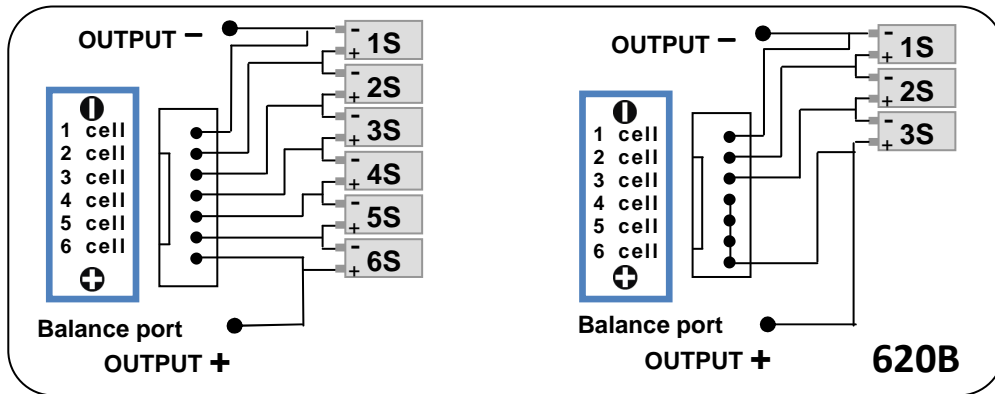

### Warning and error message

- **During charge, do not unplug the battery pack from the CY-620B, if you want to stop charging, please disconnect the DC POWER or adapter firstly, and then unplug the battery pack.**
- **Do not move the switch to change the battery type during charge. Please choose battery type before connecting the battery to the charger.**
- Choose the battery before connecting the battery to the charger.
- During charge, any cell voltage is lower than 2V/cell for LiFe battery and 2.5V/cell for LiPo battery, CY-620B will alarm and stop charging, the charging indicator blinks and the beep sounds.
- When all cell voltage are over 4.25V, all balancing LEDs will flash till the voltage under 4.25V and the cell voltage is balanced.
- When any cell voltage is over 4.30V, the charging indicator is Green, the CY-620B stop charging. The balance LEDs blink till the battery pack recovery the balance status. If the battery is balanced, all balance LEDs are off.
- Reverse polarity connection on input or output, the CY-620B will not work.

**Balance port and Individual Cell connection diagram**

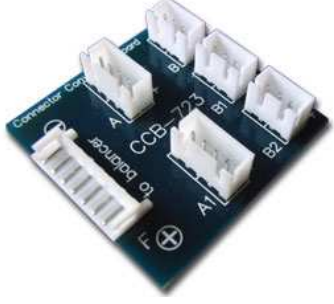

**Accessories**

<p><b>CEHN-7</b> Conversion Wire</p>	<p><b>CCB-723-EH or XH</b> for 2*3S and 3*2S Kokam and Align batteries pack</p>	<p><b>CCB-723TPQF</b> for 2*3S and 3*2S TP, Flightpower and Polyquest, Hyperion batteries pack</p>
		
<p><b>CCB-7BC</b> for 2S, 3S, 4S, 5S, 6S Thunder Power , Flightpower and Polyquest, Hyperion batteries pack</p>	<p><b>CCB-7KT-EH</b> For 2S, 3S, 4S, 5S, 6S Kokam, Graupner, <b>XH</b> for Align, Chargery batteries pack</p>	<p><b>CW9:</b> temperature sensor</p>
		

**Warnings and safety information**

- Never leave the charger unattended when it is connected to its power supply. If any malfunction is observed immediately terminated charging and refer to the operation instructions.
- Keep away the unit from dust, damp, rain, heat direct sunshine and vibration. Do not drop it.

- The charger and the battery to be charged should be set up on a head-resistant, non-inflammable and non-conductive surface. Never place them on a car seat, carpet or similar.
- Keep all the inflammable volatile materials well away from operating area.
- Do not attempt to charge the following types of battery:
  - Lead acid battery or VRLA
  - NIMH/NICd battery pack.
  - Any other types of battery except for li-ion and lithium polymer battery.
  - Battery pack, which consists of different types of cell (including different manufacturers).
  - Non-rechargeable batteries (Explosion hazard).
  - Faulty or damaged battery.
  - Batteries with unconfirmed charging current

Those warnings and safety notes are particularly important. Please follow the instructions for a maximum safety; otherwise the charger and the battery can be damaged violently. And also it can cause a fire to injure a human body or to lose the property.

### **Warranty and Service**

Chargery Power Co., Ltd. as manufacture of R/C model power warrants its CHARGER charger and battery pack to be free of defects in material and workmanship. This warranty is effective for 18 months from date of purchase. If within the warranty period the customer is not satisfied with the products performance resulting from a manufacturing defect the accessory will be replaced or repaired. This warranty does not cover the damage due to wear, overloading, incompetent handling or using of incorrect accessories.



### Balance charging connection Diagram

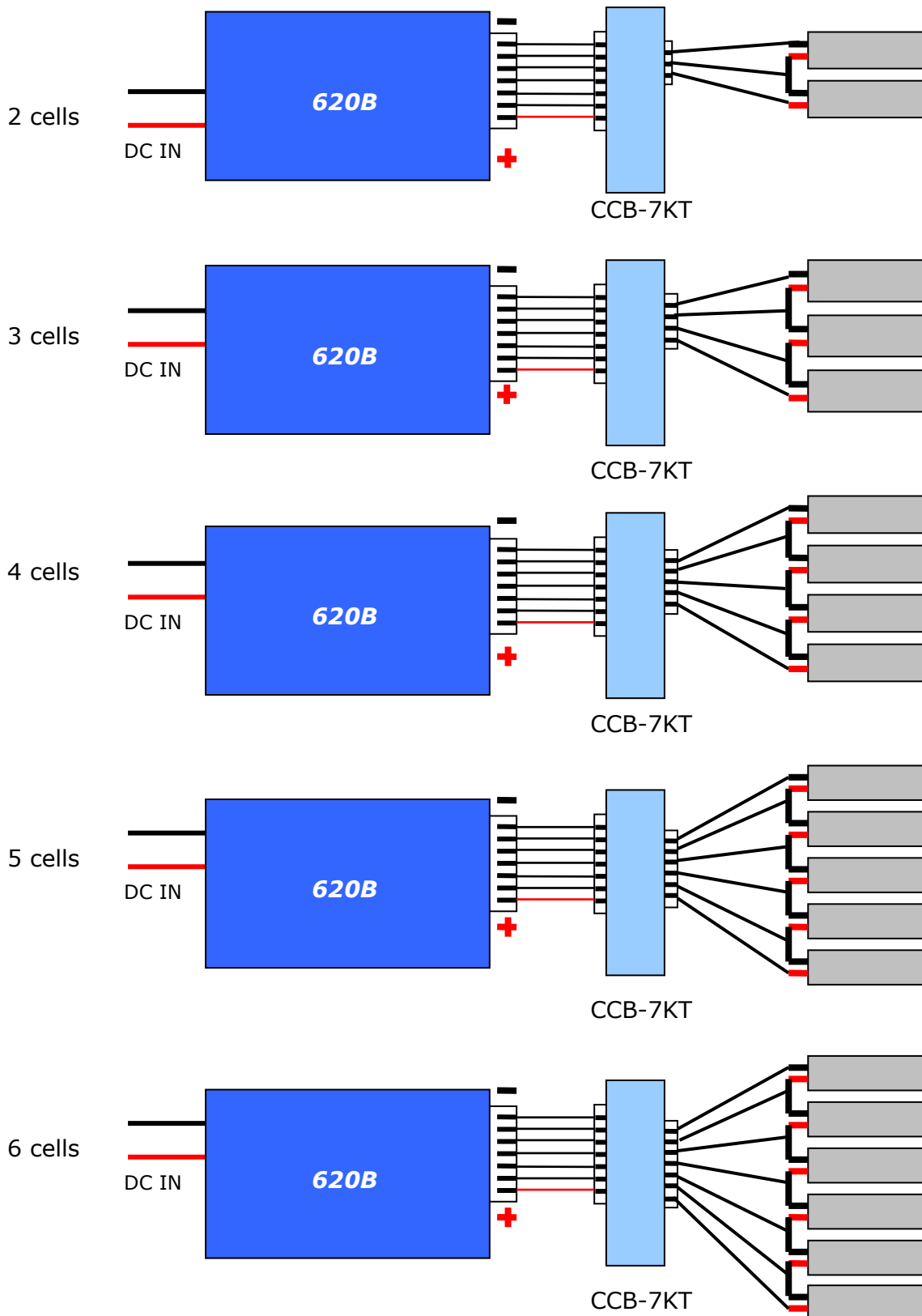

### Charge 2\*3S or 3\*2S battery packs

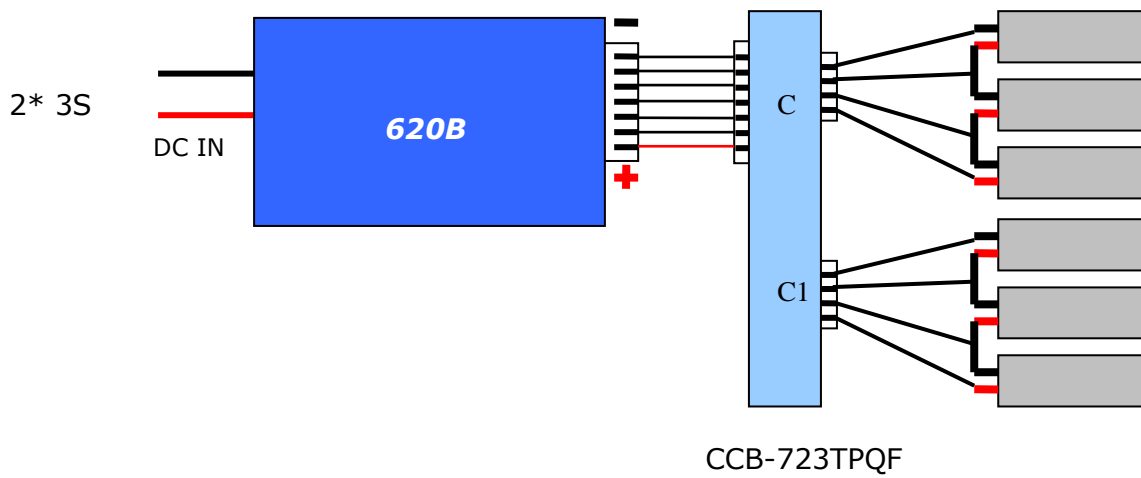
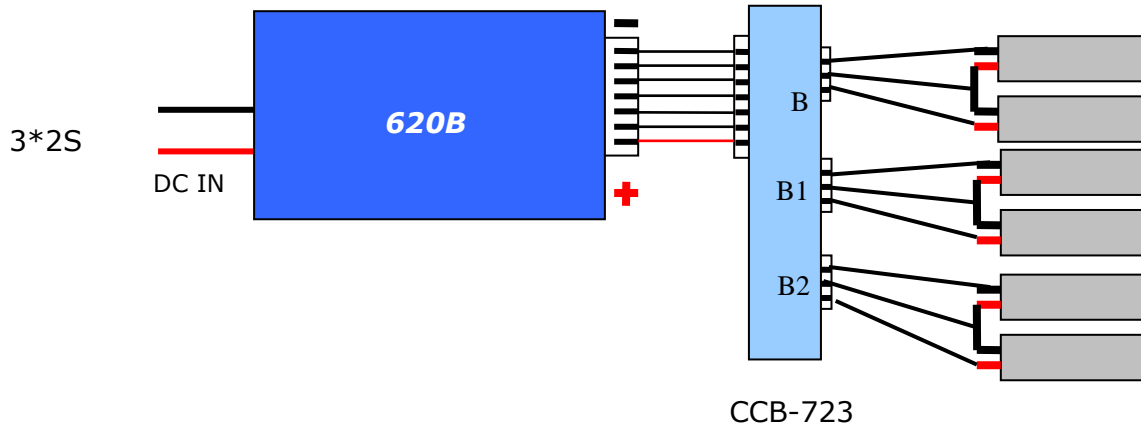



### Maximum circuit power chart

When the battery voltage is more than 25V, the actual charging current delivered to the battery will be automatically limited so as not to exceed the charger's rated charging power of 50 watts. The actual feeding current will be as follows:

#### Maximum charge current for different battery At 60W of input power

battery type	cell counts	rated voltage(V)	Charge current(A)
LiPo	2	7.4	3.0
	3	11.1	3.0
	4	14.8	3.0
	5	18.5	2.0
	6	22.2	2.0
LiFe	2	6.6	3.0
	3	9.9	3.0
	4	13.2	3.0
	5	16.5	2.0
	6	19.8	2.0