



## DCC Contactor V1.1

Bi-directional DC Contactor  
DC 100V, Up to 600A



**T**hanks for your purchasing the DC contactor.

**R**ead the ENTIRE instruction manual to become familiar with the features/functions of the device before operating.

**F**eel free to send an email to [jasonwang3a@163.com](mailto:jasonwang3a@163.com) or call at 86 755 2643 6165 should you have any questions and suggestions.

A handwritten signature in black ink, appearing to read "Jason Wang".

Jason Wang

## Features

The DC contactor is designed special work with CHARGER BMS', the following are some features:

- Bi-directional connection, one DCC can be used in a Common port such as a Solar system, instead of two SSR's (Solid State Relays) or conventional relays.
- The DCC has a Built-in the surge suppressing circuit, thereby eliminating the need for the additional Relay Delay Time board which is used to avoid a surge current when starting to charge or discharge. For other SSR's or mechanical relay, please consider the surge current potentials seriously and make a suitable plan for using a delay board as applicable.
- Over temperature protection. If internal temperatures over heat, the contactor will shut off.
- 1 Intelligent cooling fans turned on automatically
- Approved by CE
- 12 months warranty

## Application

- Home application such as Energy Storage Systems.
- Electric drive vehicles

## Main Specifcator

DC Contactor (DCC) model	DCC-100HB	DCC-200HB	DCC-300HB	DCC-600HB
Driving voltage	12V			
Holding current (Avg.) at 12V	9mA	11mA	11mA	11mA
Rated Operating Voltage	100V			
Continuous (Carry) Current, Typical	100A	200A	300A	600A
Maximum current, at 85°C for 2 seconds	200A	300A	500A	1000A
Maximum Contact voltage drop at 100A	200mV	136mV	80mV	40mV
Fan start Temperature		>42°C	>42°C	>42°C
Over temperature protection---- Turn off temperature		>90°C	>90°C	>90°C
Turn on temperature automatically		<80°C	<80°C	<80°C
Current mode	bi-directional			
Size(L*W*H, mm)	105*55*40	105*64*55	105*90*55	142*105*55
Weight(Kg)	0.3	0.45	0.7	1.2
Operating Ambient Temperature	-40 to +85 °C			
Cold pressing copper tube terminal	10-6	25-6	50-8	
Screws	M6*16		M8*20	
Wire Area(mm <sup>2</sup> ) requirements	18	30	50	70
Ambient Temperature	-10--45°C			
Ambient Humidity	5%--95%			
Storage Temp.	-20°C--70°C			
Storage Humidity	30%--90%			







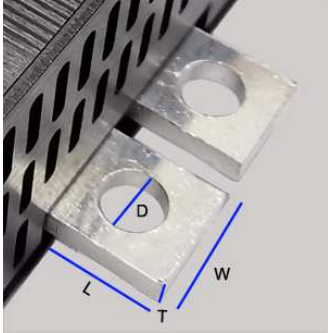

<b>Status</b> Indicator	Red LED is ON at DCC closed, and OFF at DCC open.
<b>Power</b> Indicator	Red LED is ON, The unit is ON. Red LED is OFF, means BMS has cut off charge and/or discharge, or if High/Low temperature protection has been triggered, or Temperature sensor is disconnected from the BMS.

## Chargery DCC installation details.

### Warning:

1. When installing Lugs, DO NOT Allow the lugs to make contact with the DCC Casing.
2. Do not allow the lugs to touch each other & short out.
3. The CHARGER DCC should be installed on the battery negative, after the shunt. The shunt should be between the DCC & Battery itself. If fit with our ISO board, it can be installed on battery positive side.
4. Ensure that there is Free Airflow to & from the vents on the DCC to prevent overheating.

	DCC MODEL /Terminal size	L/mm	W/mm	T/mm	D/mm	Bolt Size
	DCC-100HB	25	18	3	7	M6 - 1/4
	DCC-200HB	25	18	3	7	M6 - 1/4
	DCC-300HB	30	18	5	9	M8 - 5/16
	DCC-600HB	30	18	5	9	M8 - 5/16
						
<b>DCC-100HB, 100A</b>	<b>DCC-200HB, 200A</b>					
						
<b>DCC-300HB, 300A</b>	<b>DCC-600HB, 600A</b>					
						

DCC-600HB, 600A	BMS8T is connected to DCC-600HB
-----------------	---------------------------------

## Cold pressing copper tube lugs Specifications

These lugs will be delivered with DCC

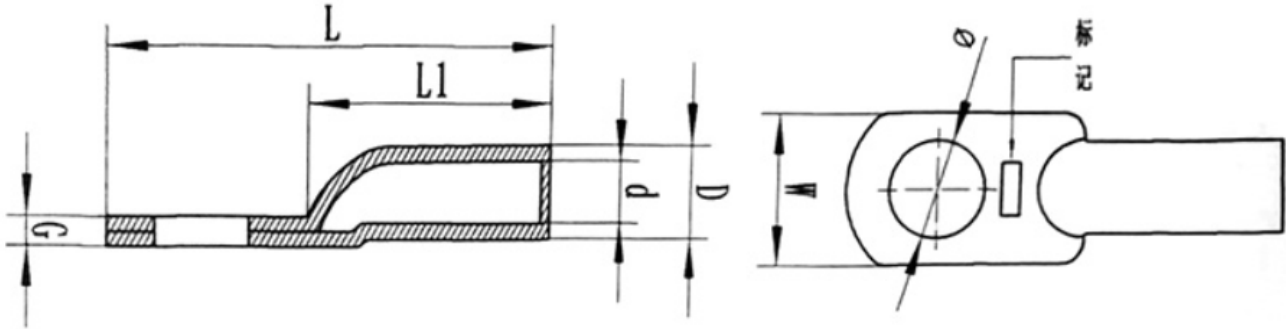

DCC model	DCC-100HB	DCC-200HB	DCC-300HB	DCC-600HB
Terminal Model	10-6	25-6	50-8	
D±0.2mm	8	10	13	
d±0.2mm	5.6	7.3	10	
<b>G±0.3mm</b>	<b>2.5</b>	<b>2.8</b>	<b>3</b>	
L±1.5mm	38	45	54	
L1±1mm	21	25	30	
W±1mm	12	14	19	
φ ±0.5mm	6.5	6.5	8.5	
Cable AWG	AWG5 (16.8mm <sup>2</sup> )	AWG2 (33.6mm <sup>2</sup> )	AWG1/0 = 0 (53.5mm <sup>2</sup> )	AWG2/0 = 00 (67.5mm <sup>2</sup> )



## **Chargery DC Contactor (DCC) Operation Instructions**

1. Connect all device according to manual. But keep all device turn off, including inverter/charger and DCC.
2. Connect Battery positive to DCC then connect to charger positive/ load positive, if possible install a fuse between DCC and battery positive.
3. Connect charger negative/load negative to shunt (shunt is connected to battery negative), the charger and / or loader/inverter can monitor battery voltage if with these device is with LCD (actual value is lower 0.5V than battery voltage), but cannot charge or discharge because of the pre-charge circuit.
4. Turn off DCC, connect BMS to ISO board, two LEDs (charge LED and discharge LED) will be on if there is not any warnings trigger on BMS, then connect to DCC, two LED is off. No charge current or discharge current flow DCC, even BMS has not any warning.
5. Turn on DCC, The power LED and STATUS LED will be on, if there is warning trigger, the Status LED is off. At the same time, one or both LED on ISO board will be OFF, the LEC can indicate charge or discharge is cutting off.
6. Turn on charger, charge current flow DCC, if over charge triggered, the charge LED on ISO board and Status LED on DCC will be off.
7. Or turn on loader/inverter, discharge current flow DCC, if over discharge/cell voltage difference/ soc /temperature etc triggered, the discharge cut off. the discharge LED on ISO board and Status LED on DCC will be off.

### **WARNING**

**DCC must be turned on finally. Otherwise the surge current may blow FUSE or other device.**

## Chargery DC Contactor (DCC) configuration

### Common and Separate Port

CHARGER Y DCC should be installed on the battery positive (**must fit with ISO board**). It has the following advantage:

- Lower holding current (under 11mA for 600A DC Contactor), save more battery energy.
- Bi-directional allows it to be used in common port and separate port configurations.
- Nothing extra is needed to have both charge and discharge control signals to control one DCC in common port application.
- The Relay Delay Time Board Even is not needed to avoid surge current, as it is built-in.

Compare with SSR (Solid State Relay), the Chargery DCC is bi-directional and can handle up to 600A current at 100V DC. **ONE** Chargery bi-directional DCC can be used in common port, and receive both HV and LV cut off signal. If not using the Chargery DCC, you would require two SSR's or two relays, which would increase power consumption and have a higher cost.

**The Chargery DCC installation diagram is as below.**



## DCC on Common port connection

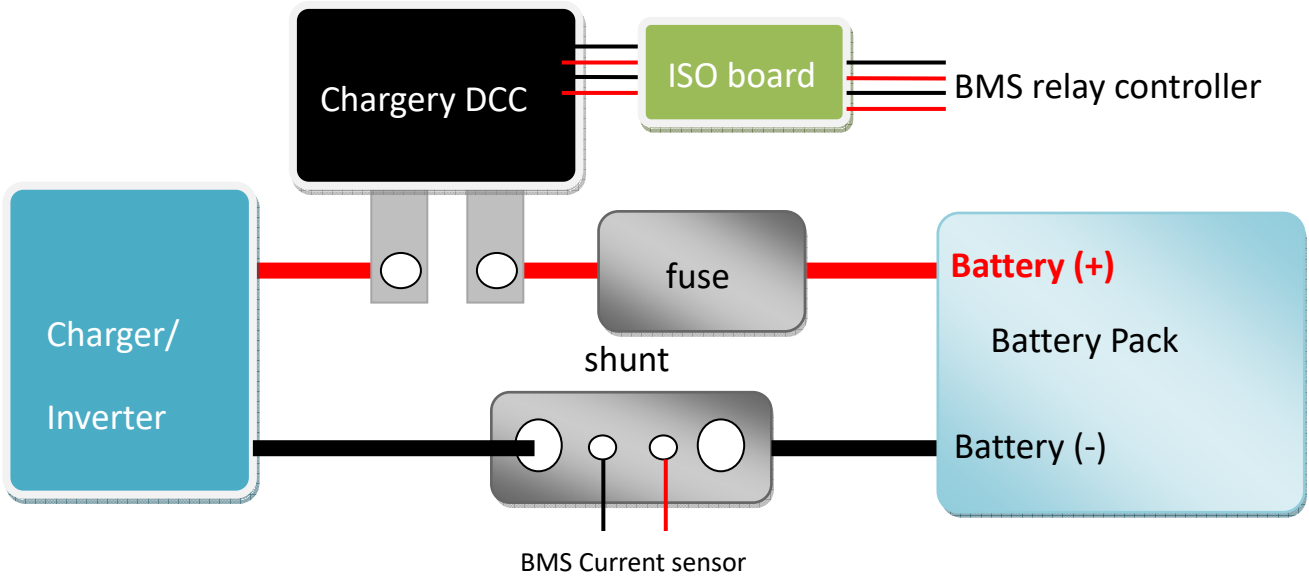

## DCC on Separate port connection

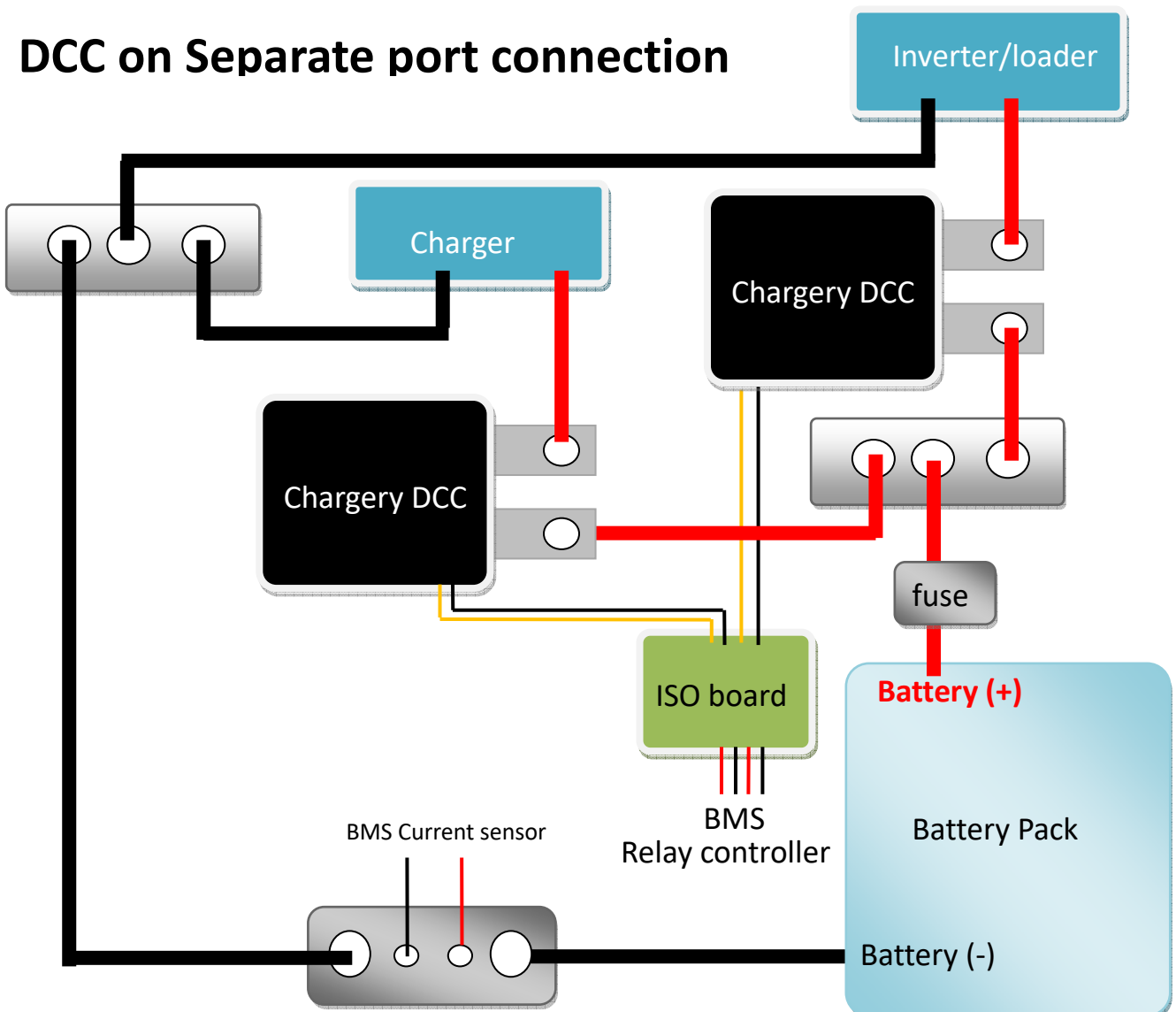



## ISO board

The board is designed special for DCC, as we know the DCC install on the positive side is better and more safe than install on negative, so we designed the board.

The board should connect between BMS relay controller port and DCC. There is two LEDs, One indicate charge control signal, another indicate discharge control signal. As below.

When over charge triggered, BMS cut off charging, the charge LED on ISO board and Status LED on DCC will be off.

When over discharge triggered, BMS cut off discharging, the discharge LED on ISO board and Status LED on DCC will be off.

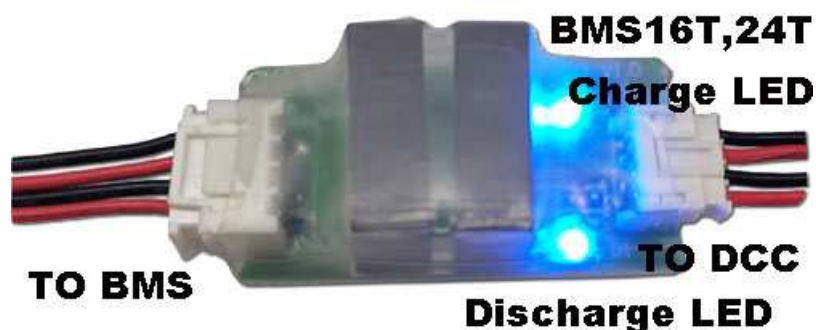
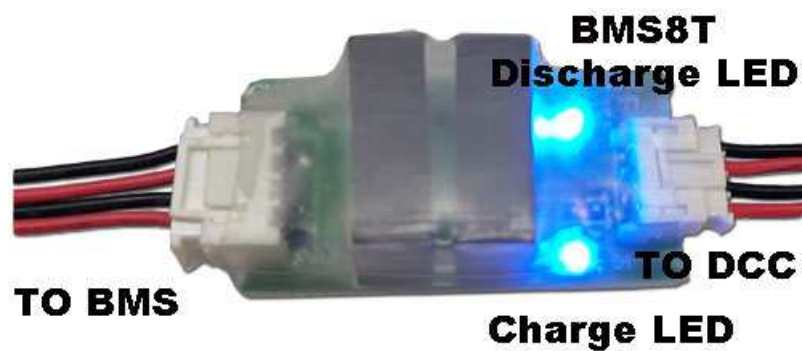

## Packaging Information

- DCC base unit: 1pcs
- Connection wire: 2pcs
- ISO board: 1pcs
- Lugs: 2 pcs
- Screws: 2 pcs



The connection wire connect BMS to ISO board or connect ISO board to one DCC on common port.

The connection wire connect ISO board to two DCC on separate port. Please identify the charge and discharge control signal.



## Warranty and Service

Chargery Power Co., Ltd. as manufacture of R/C, E-Vehicle and UAV power warrants DCC to be free of defects in material and workmanship. This warranty is effective for **12** months from date of purchase. If within the warranty period the customer is not satisfied with the products performance resulting from a manufacturing defect, the accessory will be replaced or repaired. This warranty does not cover the damage due to wear, misuse, incompetent handling or using of incorrect accessories.



### Chargery Power Co., LTD.

Tel: 86 (0)755 2643 6165, fax: 86 (0) 755 2641 2865

Email: [jasonwang3a@163.com](mailto:jasonwang3a@163.com)

Homepage: [www.chargery.com](http://www.chargery.com)

